

Data Sheet for Hino 500 Series  
GH8JM7A-PG3 (4x2)  
Hino Water Tanker 10,000 ltr

Chassis Model : Hino 51927	
Chassis Code : GH8JM7A-PG3	
Year Model: 2022 or newer	
Country of Manufacturer : Japan For Chassis & Water Tanker ( Kyokuto)	
<b>Dimensions</b>	<b>mm</b>
Overall Length ( OL)	8,460.
Overall Width ( OW)	2,490.
Overall Height (OH)	2,775.
Wheel base (WB)	5,080.
<b>Weights</b>	<b>Kg</b>
Vehicle mass	5,290.
Loading capacity ( Payload )	13,710 .
Rating Gross Vehicle Mass ( GVMR)	19,000.
<b>Engine</b>	
Model & Emission	HINO J08E-WH- EURO3.
Type	Diesel, Turbocharged and intercooled, 4cycle, in-line 6 Cylinder, overhead camshaft, water cooled. Suitable for weather and dusty area in Iraq.
Combustion system	Direct injection type.
Displacement (L)	7.684 L
Compression ratio	18.0 : 1
Maximum Power /Speed	195 kW ( 265PS ) @2,500 rpm (JIS Gross) 191 kW ( 260PS ) @2,500 rpm (ISO Net)
Maximum Torque /Speed	804 Nm ( 82kgfm ) @1,500 rpm (JIS Gross) 794 Nm ( 81kgfm ) @1,500 rpm (ISO Net)
Fuel System (Fuel injection pump)	Electronic control, common rail type, suitable for Iraqi Fuel / Diesel.
<b>Clutch</b>	
Type	CSP-380, dry single plate with damper springs.
<b>Gear Box</b>	
Model	MX06, manual 6-speeds, synchromesh 2nd-6th, overdrive.
<b>Axles</b>	

ر. مهندس اقدم  
نجم عبد سهويي  
ر. لجنة

ر. مهندس اقدم  
ماجد عزيز جبر  
عضو

ر. مهندس اقدم  
محمد عباس حسين  
عضو

ر. مهندس  
مخلد خليل اسماعيل  
عضو

ر. مهندس  
تديم محمود شاكر  
عضو

ارام سلسه عمان

**Data Sheet for Hino 500 Series  
GH8JM7A-PG3 (4x2)  
Hino Water Tanker 10,000 ltr**

<b>Front Axle</b>	
Type	Reversed Elliot, " I " section beam.
Rating Capacity ( kg)	7,500.
<b>Rear Axle</b>	
Type	Full-floating, single reduction, single speed by hypoid gearings.
Rating Capacity ( kg)	11,500.
<b>Steering</b>	
Type	LHD, Telescopic and tilt steering column, reticulating ball integral power steering.
<b>Tire &amp; Wheel</b>	
Front	Front: 315/80R22.5.
Rear	Rear: 295/80R22.5.
No. of Tires	7 (including 1 spare tire).
Wheels	Front: 22.5 x 9.00. Rear: 22.5 x 8.25. ISO 10 stud wheel.
<b>Suspension</b>	
Front	Semi-elliptic leaf springs (reinforced type) with single action shock absorbers.
Rear	Semi-elliptic main leaf springs and auxiliary springs.
<b>Braking System</b>	
Service Brake	Full air, S-cam, leading and trailing shoes, Dual circuit, <b>ABS Equipped.</b>
Parking Brake	Air operated spring brake acting on rear axle, for emergency and parking purpose.
Exhaust Brake	Equipped.
<b>Electrical</b>	
No. of Batteries	2 x 12 V ,65 Ah.
Alternator	24 V ,60Ah.
Horn	Electric Horn.
<b>Fuel tank</b>	
Capacity	200 L.

ر. مهندسين اقدم  
نجم عبد شهبوي  
ر. لجنة

ر. مهندسين اقدم  
ماجد عزيز جبر  
عضو

ر. مهندسين اقدم  
محمد عباس حسين  
عضو

ر. مهندسين  
مخلد خليل اسماعيل  
عضو

ر. مهندسين  
لاديم محمود شاكر  
عضو

ابراهيم يوسف عثمان

Data Sheet for Hino 500 Series  
GH8JM7A-PG3 (4x2)  
Hino Water Tanker 10,000 ltr

Fuel filter	Equipped with pre-filter and sedimenter.
<b>CABIN</b>	
Type	Forward control, all steel welded construction with torsion bar tilt mechanism, Semi floating (rubber mounting).
Seating capacity	Three.
Driver seat	Hlgh-back 750mm, 8-way adjustable seat.
Seat cover	Vinyl Cover.
Seatbelt	Equipped with ELR (Emergency Locking Retractor) and warning.
Sun visor	Driver side.
Windshield wiper	2-speed with wash and intermittent.
Outside rear view mirror	Equipped.
Air condition	Equipped.
Car Audio	AM/FM radio with CD player
Cigar lighter	Equipped.
Door Lock	Equipped.
Power Window	Equipped.
<b>Instrument</b>	
Speedometer	Equipped (Km/h).
Tachometer and over run warning	Equipped with buzzer.
Fuel gauge	Equipped.
Coolant level warning	Equipped.
Air pressure gauge	Equipped.

  
ر. مهندسين أقدم  
لجم عبد شهبوي  
ر. لجنة

  
ر. مهندسين أقدم  
ماجد عزيز جبر  
عضو

  
ر. مهندسين أقدم  
محمد عباس حسين  
عضو

  
ر. مهندسين  
مخلد خليل أسماعيل  
عضو

  
ر. مهندسين  
تديم محمود شاكر  
عضو

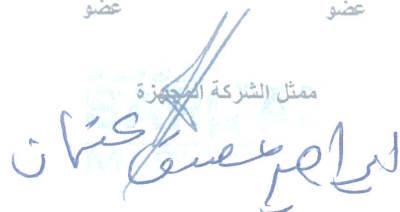
ممثل الشركة المجهزة  
  
ل. م. ع. ع. ع.

Data Sheet for Hino 500 Series  
GH8JM7A-PG3 (4x2)  
Hino Water Tanker 10,000 ltr

General Technical specifications for 10,000L KYOKUTO Non- Potable  
Water Tanker

ملاحظة: الجزء التخصصي ترك قبول مواصفاته الى الجهة المستفيدة وليس من مسؤولية اللجنة.

Make and Model: Kyokuto Japan LH10-30	
<b>GENERAL</b>	
The water tank truck is designed for transporting water effectively. Water can be loaded or unloaded by gravity or by a pump installed on the vehicle.	
<b>CAPACITY</b>	
Max. loading capacity	10,000 L
Tank volume	10,790 L
Tank weight	2,210 Kg
<b>LOAD</b>	
Suitable load	Water
<b>CONSTRUCTION &amp; DIMENSIONS</b>	
Tank Construction	Ellipse sectioned cylindrical tank with one-compartment tank with a manhole hatch equipped with an air breather
<b>Manhole</b>	
Hatch type	1
Closed type	1
Internal surface treatment	Zinc metal spraying
Dimensions (Inside)	
Length	5,510 mm
width	2,200 mm
Height	1,150 mm
Material & Thickness	
Shell	Mild steel plate 3.2 mm
End plate	Mild steel plate 3.2 mm
Buffer plate	Mild steel plate 3.2 mm
Piping	Steel pipe
<b>Pump</b>	
Type	Centrifugal pump

ر. مهندسين اقدم  
نجم عبد شهابي  
ر. لجنة

ر. مهندسين اقدم  
ماجد عزيز جبر  
عضو

ر. مهندسين اقدم  
محمد عباس حسين  
عضو

ر. مهندسين  
مخلد خليل اسماعيل  
عضو

ر. مهندسين  
تديم محمود شاكر  
عضو

امير احمد

Data Sheet for Hino 500 Series  
GH8JM7A-PG3 (4x2)  
Hino Water Tanker 10,000 ltr

Capacity	Approx. 600 L/min at 2500 r/min (as an independent performance)
<b>Piping: for details see piping diagram</b>	
Piping material	Steel pipe
Water supply piping (only unloads by gravity)	
Supply port	4
Port size	¾ inch
<b>Power Train</b>	
Transmission P.T.O → Drive Shaft → Pulley & V-belt → Pump	
<b>Control</b>	
P.T.O Control	Switch installed in a cab
<b>Accessories</b>	
• Suction hose: 63.5mm 12.5 in X 3m	2
• Hose packing (Spare)	3
• Hose wrench	2
• Strainer for hose	1
• Tool box	1
• Hose box	2
• Spare tire carrier	1
• Level gauge	1

ر. مهندسين أقدم  
نجم عبد شهبوي  
ر. لجنة

ر. مهندسين أقدم  
ماجد عزيز جبر  
عضو

ر. مهندسين أقدم  
محمد عباس حسين  
عضو

ر. مهندسين  
مخالد خليل اسماعيل  
عضو

ر. مهندسين  
نديم محمود شاكر  
عضو

ممثل الشركة المجهزة  
ارام محمد عثمان

Data Sheet for Hino 500 Series  
GH8JM7A-PG3 (4x2)  
Hino Water Tanker 10,000 ltr

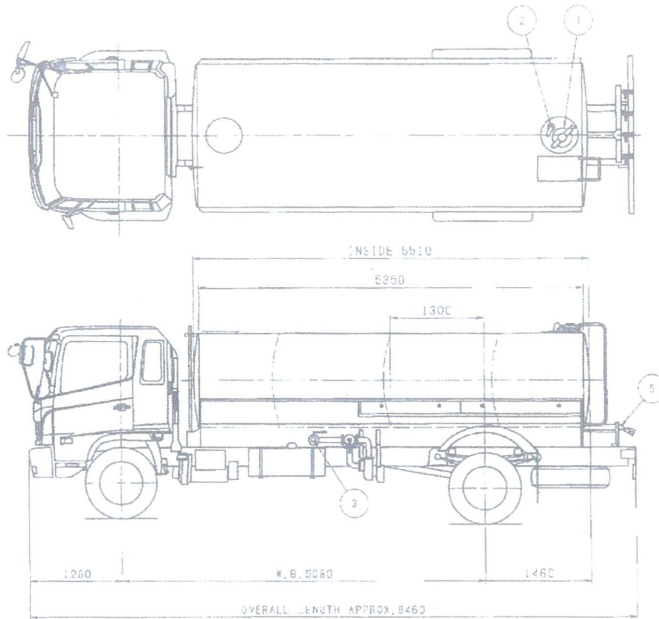

No.	NOMENCLATURE
1	FILLING PORT
2	AIR BREATHER
3	INLET & OUTLET HOSE JOINT
4	HOSE
5	WATER SUPPLY PIPING

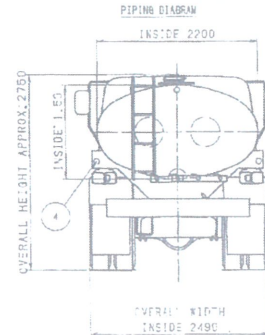
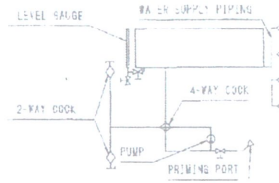

ر. مهندسين أقدم  
نجم عبد شهبوي  
ر. لجنة

ر. مهندسين أقدم  
ماجد عزيز جبر  
عضو

ر. مهندسين أقدم  
محمد عباس حسين  
عضو

ر. مهندسين  
مخلد خليل أسماعيل  
عضو

ر. مهندسين  
لاديم محمود شاكر  
عضو

البرام صديق عثمان